

## 8-INPUT MULTIPLEXER

### DESCRIPTION

The T54LS151/T74LS151 is a high speed 8-Input Digital Multiplexer. It provides in one package, the ability to select one bit of data from up to eight sources. The LS151 can be a universal function generator to generate any logic function of four variables. Both assertion and negation outputs are provided.

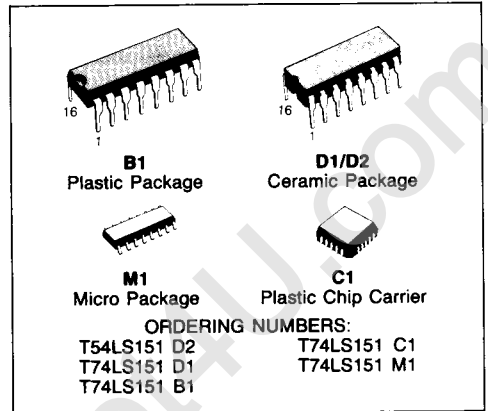

- SCHOTTKY PROCESS FOR HIGH SPEED
- MULTIFUNCTION CAPABILITY
- ON-CHIP SELECT LOGIC DECODING
- FULLY BUFFERED COMPLEMENTARY OUTPUTS
- INPUT CLAMP DIODES LIMIT HIGH SPEED TERMINATION EFFECTS
- FULLY TTL AND CMOS COMPATIBLE

### PIN NAMES

$S_0$ - $S_2$	Select Input
$\bar{E}$	Enable (Active LOW) Input
$I_0$ - $I_7$	Multiplexer Inputs
Z	Multiplexer Output
$\bar{Z}$	Complementary Multiplexer Output

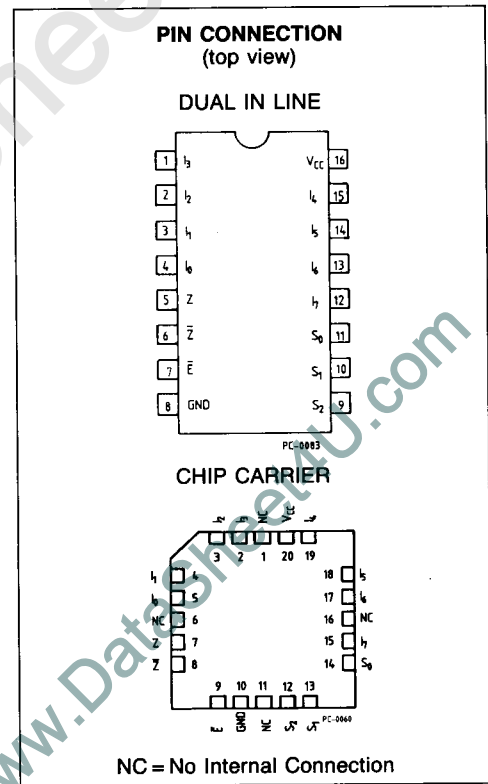



## LOGIC SYMBOL AND LOGIC DIAGRAM

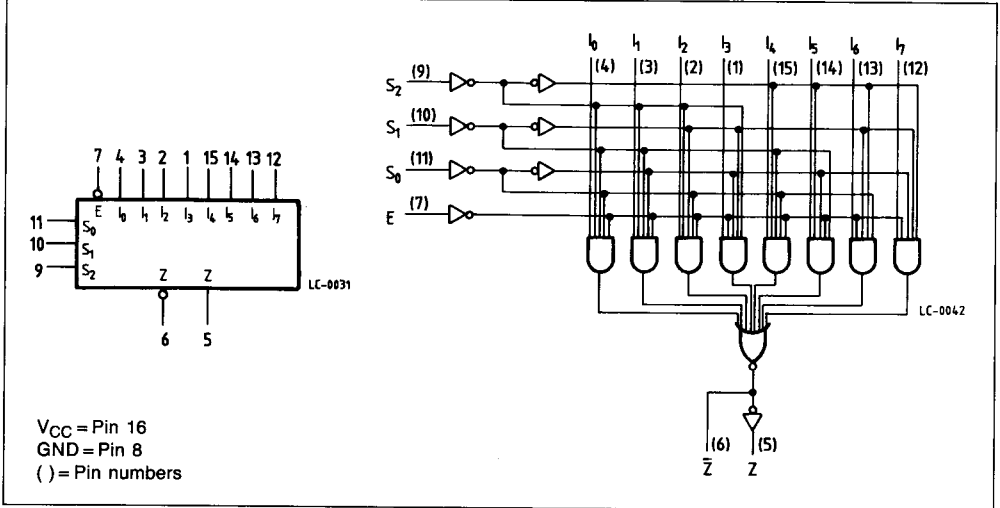

## ABSOLUTE MAXIMUM RATINGS

Symbol	Parameter	Value	Unit
V <sub>CC</sub>	Supply Voltage	-0.5 to 7	V
V <sub>I</sub>	Input Voltage, Applied to Input	-0.5 to 15	V
V <sub>O</sub>	Output Voltage, Applied to Output	-0.6 to 5.5	V
I <sub>I</sub>	Input Current, Into Inputs	-0.5 to 5	mA
I <sub>O</sub>	Output Current, Into Outputs	50	mA

Stresses in excess of those listed under "Absolute Maximum Ratings" may cause permanent damage to the device. This is a stress rating only and functional operation of the device at these or any other conditions in excess of those indicated in the operational sections of this specification is not implied. Exposure to absolute maximum rating conditions for extended periods may affect device reliability.

## GUARANTEED OPERATING RANGES

Part Numbers	Supply Voltage			Temperature
	Min	Typ	Max	
T54LS151D2	4.5 V	5.0 V	5.5 V	-55°C to +125°C
T74LS151XX	4.75 V	5.0 V	5.25 V	0°C to +70°C

XX = package type.



## FUNCTIONAL DESCRIPTION

The LS151 is a logical implementation of a single pole, 8-position switch with the switch position controlled by the state of three Select inputs,  $S_0$ ,  $S_1$ ,  $S_2$ . Both assertion and negation outputs are pro-

vide. The Enable input (E) is active LOW. When it is not activated, the negation output is HIGH and the assertion output is LOW regardless of all other inputs. The logic functions provided at the output is:

$$Z = \bar{E} \cdot (I_0 \cdot \bar{S}_0 \cdot \bar{S}_1 \cdot \bar{S}_2 + I_1 \cdot S_0 \cdot \bar{S}_1 \cdot \bar{S}_2 + I_2 \cdot \bar{S}_0 \cdot S_1 \cdot \bar{S}_2 + I_3 \cdot S_0 \cdot S_1 \cdot \bar{S}_2 + I_4 \cdot \bar{S}_0 \cdot \bar{S}_1 \cdot S_2 + I_5 \cdot S_0 \cdot \bar{S}_1 \cdot S_2 + I_6 \cdot \bar{S}_0 \cdot S_1 \cdot S_2 + I_7 \cdot S_0 \cdot S_1 \cdot S_2)$$

The LS151 provides the ability, in one package, to select from eight sources of data or control information. By proper manipulation of the inputs, the

LS151 can provide any logic function of four variables and its negation.

## TRUTH TABLE

$\bar{E}$	$S_2$	$S_1$	$S_0$	$I_0$	$I_1$	$I_2$	$I_3$	$I_4$	$I_5$	$I_6$	$I_7$	$\bar{Z}$	Z
H	X	X	X	X	X	X	X	X	X	X	X	H	L
L	L	L	L	L	X	X	X	X	X	X	X	H	L
L	L	L	L	H	X	X	X	X	X	X	X	L	H
L	L	L	H	X	L	X	X	X	X	X	X	H	L
L	L	L	H	X	X	L	X	X	X	X	X	H	L
L	L	H	L	X	X	H	X	X	X	X	X	L	H
L	L	H	H	X	X	X	L	X	X	X	X	H	L
L	L	H	H	X	X	X	H	X	X	X	X	L	H
L	H	L	L	X	X	X	X	L	X	X	X	H	L
L	H	L	L	X	X	X	X	H	X	X	X	L	H
L	H	L	H	X	X	X	X	X	L	X	X	H	L
L	H	L	H	X	X	X	X	X	H	X	X	L	H
L	H	H	L	X	X	X	X	X	X	L	X	H	L
L	H	H	L	X	X	X	X	X	X	H	X	L	H
L	H	H	H	X	X	X	X	X	X	X	L	H	L
L	H	H	H	X	X	X	X	X	X	X	H	L	H

H = HIGH Voltage Level

L = LOW Voltage Level

X = Don't Care

## AC WAVEFORMS

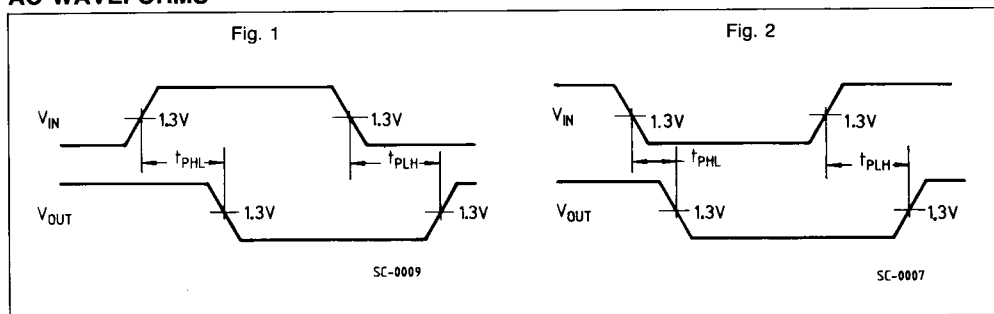

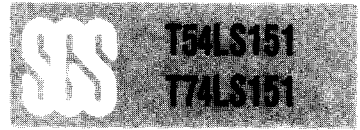

### DC CHARACTERISTICS OVER OPERATING TEMPERATURE RANGE

Symbol	Parameter		Limits			Test Conditions (Note 1)		Units	
			Min.	Typ.	Max.				
V <sub>IH</sub>	Input HIGH Voltage		2.0			Guaranteed input HIGH Threshold Voltage for all Inputs		V	
V <sub>IL</sub>	Input LOW Voltage	54			0.7	Guaranteed input LOW Threshold Voltage for all Inputs		V	
		74			0.8				
V <sub>CD</sub>	Input Clamp Diode Voltage			-0.65	-1.5	V <sub>CC</sub> = MIN, I <sub>IN</sub> = -18mA		V	
V <sub>OH</sub>	Output HIGH Voltage	54	2.5	3.4		V <sub>CC</sub> = MIN, I <sub>OH</sub> = -400μA, V <sub>IN</sub> = V <sub>IH</sub> or V <sub>IL</sub> per Truth Table		V	
		74	2.7	3.4					
V <sub>OL</sub>	Output LOW Voltage	54,74		0.25	0.4	I <sub>OL</sub> = 4.0mA I <sub>OL</sub> = 8.0mA	V <sub>CC</sub> = MIN, V <sub>IN</sub> = V <sub>IH</sub> or V <sub>IL</sub> per Truth Table		V
		74		0.35	0.5				
I <sub>IH</sub>	Input HIGH Current			1.0	20 0.1	V <sub>CC</sub> = MAX, V <sub>IN</sub> = 2.7V V <sub>CC</sub> = MAX, V <sub>IN</sub> = 7.0V		μA mA	
I <sub>IL</sub>	Input LOW Current				-0.4	V <sub>CC</sub> = MAX, V <sub>IN</sub> = 0.4V		mA	
I <sub>OS</sub>	Output Short Circuit Current (Note 2)		-20		-100	V <sub>CC</sub> = MAX, V <sub>OUT</sub> = 0V		mA	
I <sub>CC</sub>	Power Supply Current			6.0	10	V <sub>CC</sub> = MAX		mA	

### AC CHARACTERISTICS: T<sub>A</sub> = 25°C

Symbol	Parameter		Limits			Test Conditions		Units
			Min.	Typ.	Max.			
t <sub>PLH</sub> t <sub>PHL</sub>	Propagation Delay, Select to Z̄ Output			14 20	23 32	Fig. 1	V <sub>CC</sub> = 5.0V C <sub>L</sub> = 15pF	ns
t <sub>PLH</sub> t <sub>PHL</sub>	Propagation Delay, Select to Z Output			27 18	43 30	Fig. 2		ns
t <sub>PLH</sub> t <sub>PHL</sub>	Propagation Delay, Enable to Z̄ Output			15 18	24 30	Fig. 2		ns
t <sub>PLH</sub> t <sub>PHL</sub>	Propagation Delay, Enable to Z Output			26 20	42 32	Fig. 1		ns
t <sub>PLH</sub> t <sub>PHL</sub>	Propagation Delay, Data to Z̄ Output			13 12	21 20	Fig. 1		ns
t <sub>PLH</sub> t <sub>PHL</sub>	Propagation Delay, Data to Z Output			20 16	32 26	Fig. 2		ns

**Notes:**

- 1) Conditions for testing, not shown in the Table, are chosen to guarantee operation under "worst case" conditions.
- 2) Not more than one output should be shorted at a time.
- 3) Typical values are at V<sub>CC</sub> = 5.0V, T<sub>A</sub> = 25°C.